

All data in this brochure are general information and shall not be regarded as contractual documents.
We reserve the right to make any change due to technical improvement without prior notice.

BORCHE



Aug 2022

BORCH MACHINERY CO., LTD.

No.9 Xinxiang Road, Zengcheng Economic & Technological
Development District, Guangzhou, Guangdong Province, P.R.C.
www.borche.cn 400-655-9488



Website



Wechat

Universal Type Interconnected IMM Bi-M Series

20 Years' Dedication to Upgrade a Classic Intelligent IMM

BORCHE

Bi-M

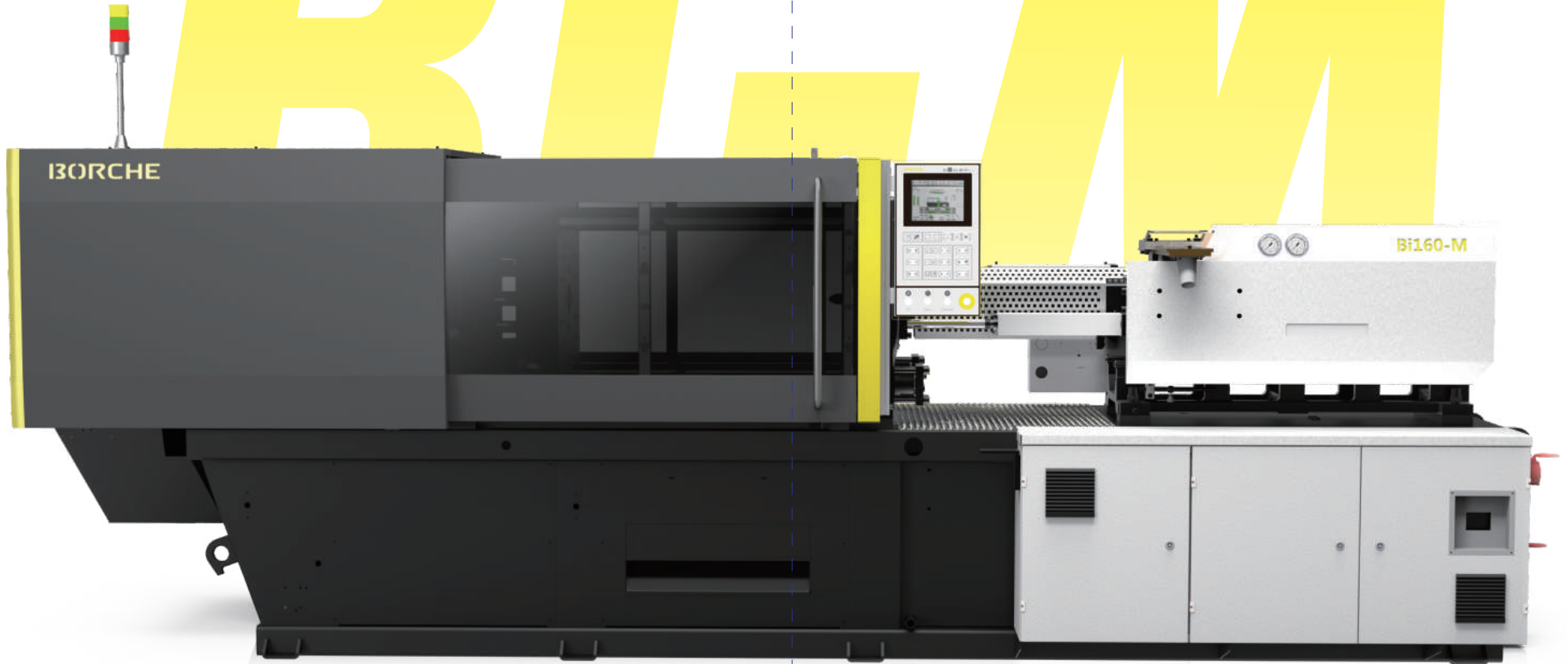

High Versatility

Modular Design

Interconnected

Upgraded Performance

High Versatility

Bi-M series originates from Borsche 20 year's intelligent IMM technology and innovation. It has advantages of strong power, precise control, stable performance, high versatility to meet different production requirements.



Modular Design

- ◆ Modular design to meet different needs flexibly
- ◆ Different size injection units to cover bigger range of injection volume
- ◆ Optional swing injection unit for easy maintenance of screw and barrel set
- ◆ Spare installation places for sockets

	1	2	3	4	5	6	7	8	9
	255	435	630	850	1360	2240	3260	3920	1830
Clamping Unit	90								
	130								
	160								
	200								
	260								
	320								
	400								
500									

Interconnected

- ◆ Intelligent & professional control system with user-friendly operation page, compatible with international standard interface, to meet customers' needs of factory digitization.
- ◆ The built-in intelligent management system can monitor the working state of key parts of injection molding machine in real-time, and realize equipment health self-diagnosis.



Upgraded Performance

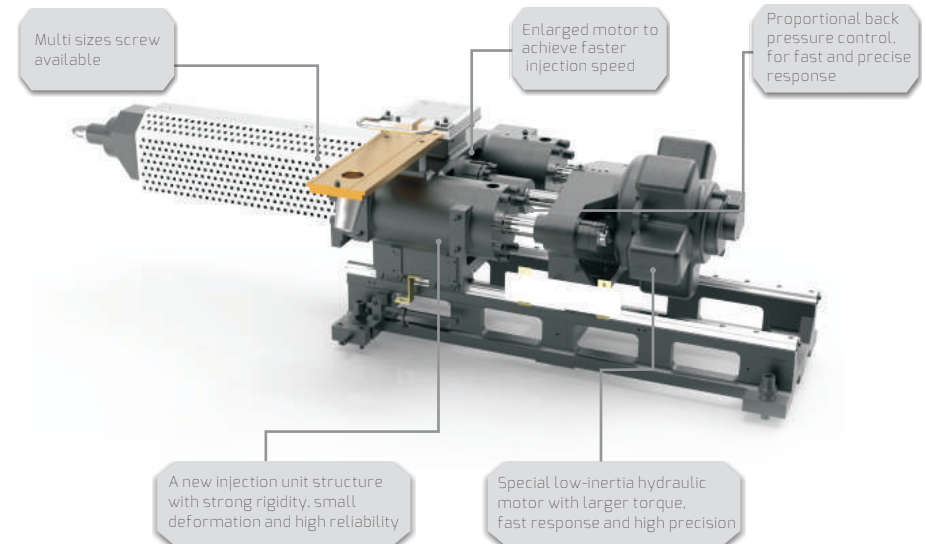

Specification

BORCHE

Model	unit	Bi90-M			Bi130-M			Bi160-M			Bi200-M		Bi260-M				Bi320-M			Bi400-M			Bi500-M			
International Class No.		255/90			435/130			630/160			850/200		1360/260				2240/320			3260/400			3920/500			
INJECTION UNIT																										
Screw Diameter	mm	30	35	40	35	40	45	40	45	50	45	50		60	50	60	70	60	70	80	70	80	90	75	85	95
Shot Volume	cm ³	120	163	213	182	238	302	270	341	422	389	481		692	589	848	1154	989	1346	1759	1539	2010	2544	1877	2411	3012
Shot Weight(PS)	g	113	153	199	166	217	275	254	321	397	365	452		650	552	800	1085	928	1266	1652	1446	1890	2366	1764	2267	2830
Shot Weight(PS)	OZ	3.9	5.2	6.8	5.8	7.6	9.7	9	11.3	14	12.9	16		23	19.5	28.3	38.3	32.8	44.7	58.4	51.1	66.8	82.5	62.3	80.1	100
Injection Pressure	Mpa	209	154	118	240	183	145	235	185	150	218	176		123	232	161	118	226	166	127	212	162	128	209	163	130
Screw L/D Ratio	L/d	24	20.4	18	23.2	20.5	18	22.7	20.2	18	23	20.5		16.9	25.7	21.2	18.1	24.8	21.3	18.6	24.3	21.3	18.7	13.8	21	18.8
Injection Stroke	mm	170			190			215			245			300				350			400			425		
Injection Rotary Speed	rpm/min	250			250			250			185			180				166			140			144		
Nozzle Contact Force	kN	30			30			30			30			40				70			80			80		
Nozzle Stroke	mm	250			250			250			280			350				360			395			450		
CLAMPING UNIT																										
Clamping Force	kN	900			1300			1600			2000			2600				3200			4000			5000		
Opening Stroke	mm	320			340			410			465			520				580			655			755		
Platen Size	mmxmm	540x540			610x610			670x670			750x750			835x835				940x940			1060x1030			1175x1145		
Space btw Tie Bars	mmxmm	360x360			410x410			460x460			510x510			575x575				670x670			730x700			830x800		
Max.Daylight	mm	680			790			910			1015			1120				1235			1375			1555		
Mold Thickness(min.-max.)	mm	130-360			145-450			160-500			180-550			195-600				220-655			245-720			265-800		
Ejection Stroke	mm	100			100			130			150			180				180			205			250		
Ejection Force	kN	28.5			34.4			41.6			49.5			77.3				77.3			111.3			111.3		
Ejector Pin	unit	4+1			4+1			4+1			4+1			8+4+1				8+4+1			8+4+1			8+4+1		
POWER UNIT																										
System Pressure	Mpa	14.5			17.5			17.5			17.5			17.5				17.5			17.5			17.5		
Pump Motor	kW	15			18.5			22			30			37				45			55			30+37		
Heating Capacity	kW	6.5			8.8			9.6			10.4			16.2				18.5			24.5			31.7		
No.of Heater Zones	unit	4			4			5			5			6				6			6			6		
GENERAL UNIT																										
Oil Tank Capacity	L	130			160			200			270			340				530			610			690		
Machine Dimensions	m*m*m	4.22x1.24x1.7			4.25x1.28x1.77			4.75x1.4x1.89			5.35x1.52x1.99			6.13x1.63x2.03				6.8x1.75x2.1			7.78x1.9x2.24			8.33x2.1x2.21		
Machine Weight	kg	3000			3500			4300			5900			8200				11000			15200			18000		

We reserve the right to make any change due to technical improvement without prior notice.

Specification

Model	Unit	Bi160-M		
International Class No.		630/160		
INJECTION UNIT				
Screw Diameter	mm	40	45	50
Shot Volume	cm ³	270	341	422
Shot Weight(PS)	g	254	321	397
Shot Weight(PS)	OZ	9	11.3	14
Injection Pressure	Mpa	235	185	150
Screw L/D Ratio	L/d	22.7	20.2	18
Injection Stroke	mm	215		
Injection Rotary Speed	rpm/min	250		
Nozzle Contact Force	kN	30		
Nozzle Stroke	mm	250		
CLAMPING UNIT				
Clamping Force	kN	1600		
Opening Stroke	mm	410		
Platen Size	mmxmm	670x670		
Space btw Tie Bars	mmxmm	460x460		
Max Daylight	mm	910		
Mold Thickness(min.-max.)	mm	160-500		
Ejection Stroke	mm	130		
Ejection Force	kN	41.6		
Ejector Pin	unit	4+1		
POWER UNIT				
System Pressure	Mpa	17.5		
Pump Motor	kW	22		
Heating Capacity	kW	9.6		
No. of Heater Zones	unit	5		
GENERAL UNIT				
Oil Tank Capacity	L	200		
Machine Dimensions	m*m*m	4.75x1.4x1.89		
Machine Weight	kg	4300		

Appearance and Installation Dimensions

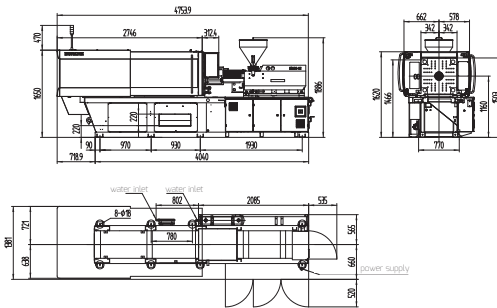

Mold Platen Drawing

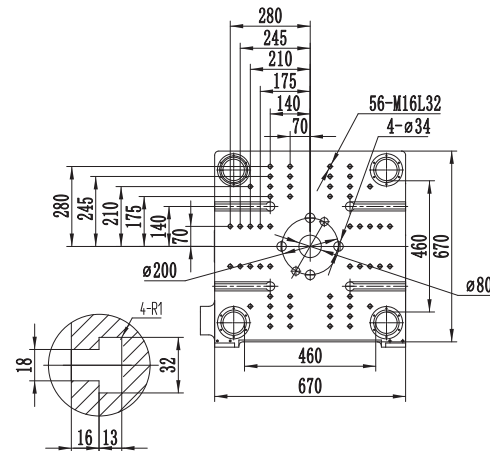

Specification

Model	Unit	Bi200-M		
International Class No.		850/200		
INJECTION UNIT				
Screw Diameter	mm	45	50	60
Shot Volume	cm ³	389	481	692
Shot Weight(PS)	g	365	452	650
Shot Weight(PS)	OZ	12.9	16	23
Injection Pressure	Mpa	218	176	123
Screw L/D Ratio	L/d	23	20.5	16.9
Injection Stroke	mm	245		
Injection Rotary Speed	rpm/min	185		
Nozzle Contact Force	kN	30		
Nozzle Stroke	mm	280		
CLAMPING UNIT				
Clamping Force	kN	2000		
Opening Stroke	mm	465		
Platen Size	mmxmm	750x750		
Space btw Tie Bars	mmxmm	510x510		
Max Daylight	mm	1015		
Mold Thickness(min.-max.)	mm	180-550		
Ejection Stroke	mm	150		
Ejection Force	kN	49.5		
Ejector Pin	unit	4+1		
POWER UNIT				
System Pressure	Mpa	17.5		
Pump Motor	kW	30		
Heating Capacity	kW	10.4		
No. of Heater Zones	unit	5		
GENERAL UNIT				
Oil Tank Capacity	L	270		
Machine Dimensions	m*m*m	5.35x1.52x1.99		
Machine Weight	kg	5900		

Appearance and Installation Dimensions

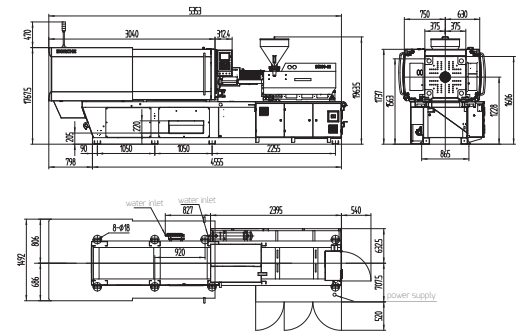

Mold Platen Drawing

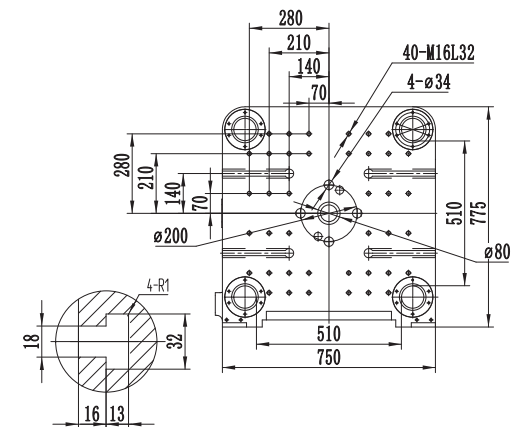

Bi260-M

BORCHE

Specification

Model	Unit	Bi260-M		
International Class No.		1360/260		
INJECTION UNIT				
Screw Diameter	mm	50	60	70
Shot Volume	cm ³	589	848	1154
Shot Weight(PS)	g	552	800	1085
Shot Weight(PS)	OZ	19.5	28.3	38.3
Injection Pressure	Mpa	232	161	118
Screw L/D Ratio	L/d	25.7	21.2	18.1
Injection Stroke	mm	300		
Injection Rotary Speed	rpm/min	180		
Nozzle Contact Force	kN	40		
Nozzle Stroke	mm	350		
CLAMPING UNIT				
Clamping Force	kN	2600		
Opening Stroke	mm	520		
Platen Size	mmxmm	835x835		
Space btw Tie Bars	mmxmm	575x575		
Max Daylight	mm	1120		
Mold Thickness(min.-max.)	mm	195-600		
Ejection Stroke	mm	180		
Ejection Force	kN	77.3		
Ejecton Pin	unit	8+4+1		
POWER UNIT				
System Pressure	Mpa	17.5		
Pump Motor	kW	37		
Heating Capacity	kW	16.2		
No.of Heater Zones	unit	6		
GENERAL UNIT				
Oil Tank Capacity	L	340		
Machine Dimensions	m*m*m	6.13x1.63x2.03		
Machine Weight	kg	8200		

Appearance and Installation Dimensions

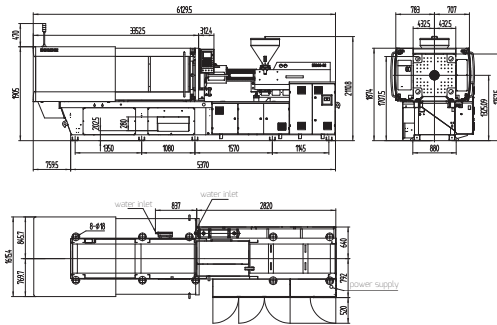

Mold Platen Drawing

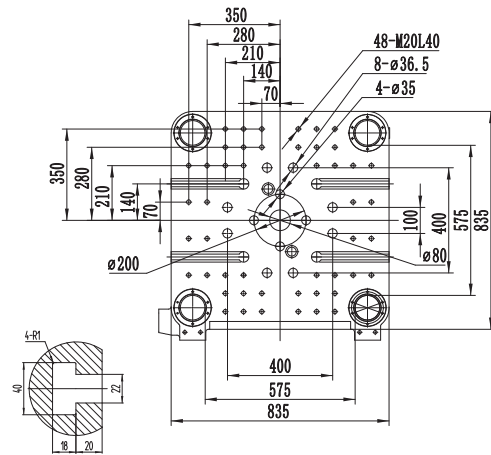

Bi320-M

BORCHE

Specification

Model	Unit	Bi320-M		
International Class No.		2240/320		
INJECTION UNIT				
Screw Diameter	mm	60	70	80
Shot Volume	cm ³	989	1346	1759
Shot Weight(PS)	g	928	1266	1652
Shot Weight(PS)	OZ	32.8	44.7	58.4
Injection Pressure	Mpa	226	166	127
Screw L/D Ratio	L/d	24.8	21.3	18.6
Injection Stroke	mm	350		
Injection Rotary Speed	rpm/min	166		
Nozzle Contact Force	kN	70		
Nozzle Stroke	mm	360		
CLAMPING UNIT				
Clamping Force	kN	3200		
Opening Stroke	mm	580		
Platen Size	mmxmm	940x940		
Space btw Tie Bars	mmxmm	670x670		
Max Daylight	mm	1235		
Mold Thickness(min.-max.)	mm	220-655		
Ejection Stroke	mm	180		
Ejection Force	kN	77.3		
Ejecton Pin	unit	8+4+1		
POWER UNIT				
System Pressure	Mpa	17.5		
Pump Motor	kW	45		
Heating Capacity	kW	18.5		
No.of Heater Zones	unit	6		
GENERAL UNIT				
Oil Tank Capacity	L	530		
Machine Dimensions	m*m*m	6.8x1.75x2.1		
Machine Weight	kg	11000		

Appearance and Installation Dimensions

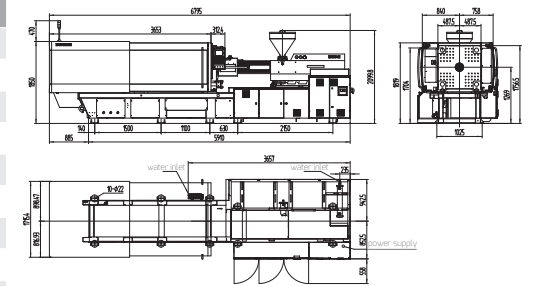

Mold Platen Drawing

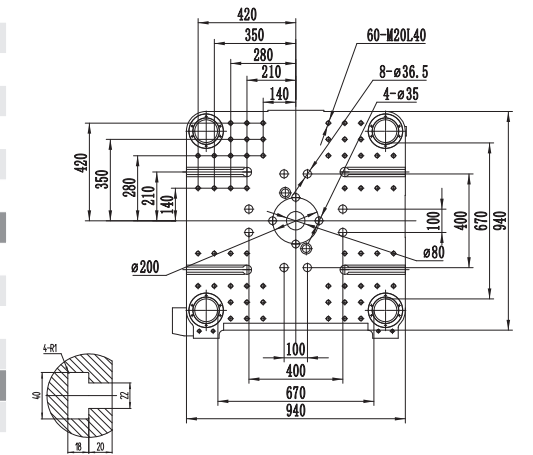

Specification

Model	Unit	Bi400-M		
International Class No.		3260/400		
INJECTION UNIT				
Screw Diameter	mm	70	80	90
Shot Volume	cm ³	1539	2010	2544
Shot Weight(P5)	g	1446	1890	2366
Shot Weight(P5)	OZ	51.1	66.8	82.5
Injection Pressure	Mpa	212	162	128
Screw L/D Ratio	L/d	24.3	21.3	18.7
Injection Stroke	mm	400		
Injection Rotary Speed	rpm/min	140		
Nozzle Contact Force	kN	80		
Nozzle Stroke	mm	395		
CLAMPING UNIT				
Clamping Force	kN	4000		
Opening Stroke	mm	655		
Platen Size	mmxmm	1060x1030		
Space btw Tie Bars	mmxmm	730x700		
Max Daylight	mm	1375		
Mold Thickness(min.-max.)	mm	245-720		
Ejection Stroke	mm	205		
Ejection Force	kN	111.3		
Ejector Pin	unit	8+4+1		
POWER UNIT				
System Pressure	Mpa	17.5		
Pump Motor	kW	55		
Heating Capacity	kW	24.5		
No. of Heater Zones	unit	6		
GENERAL UNIT				
Oil Tank Capacity	L	610		
Machine Dimensions	m*m*m	7.78x1.9x2.24		
Machine Weight	kg	15200		

Appearance and Installation Dimensions

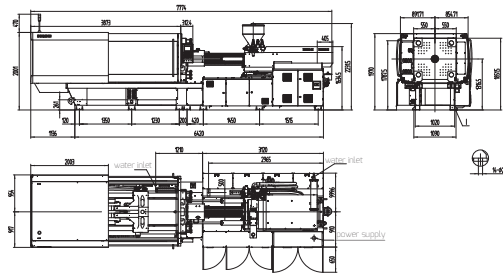

Mold Platen Drawing

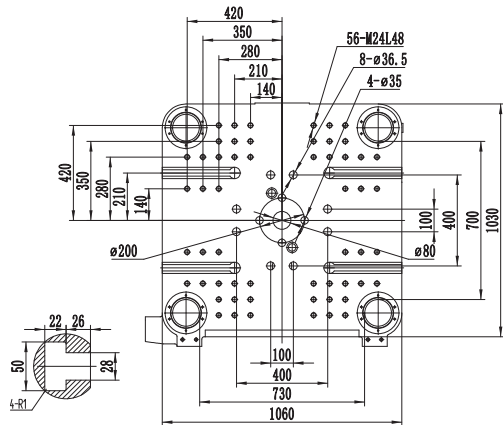

Specification

Model	Unit	Bi500-M		
International Class No.		3920/500		
INJECTION UNIT				
Screw Diameter	mm	75	85	95
Shot Volume	cm ³	1877	2411	3012
Shot Weight(P5)	g	1764	2267	2830
Shot Weight(P5)	OZ	62.3	80.1	100
Injection Pressure	Mpa	209	163	130
Screw L/D Ratio	L/d	13.8	21	18.8
Injection Stroke	mm	425		
Injection Rotary Speed	rpm/min	144		
Nozzle Contact Force	kN	80		
Nozzle Stroke	mm	450		
CLAMPING UNIT				
Clamping Force	kN	5000		
Opening Stroke	mm	755		
Platen Size	mmxmm	1175x1145		
Space btw Tie Bars	mmxmm	830x800		
Daylight Max	mm	1555		
Mold Thickness(min.-max.)	mm	265-800		
Ejection Stroke	mm	250		
Ejection Force	kN	111.3		
Ejector Pin	unit	8+4+1		
POWER UNIT				
System Pressure	Mpa	17.5		
Pump Motor	kW	30+37		
Heating Capacity	kW	31.7		
No. of Heater Zones	unit	6		
GENERAL UNIT				
Oil Tank Capacity	L	690		
Machine Dimensions	m*m*m	8.33x2.1x2.21		
Machine Weight	kg	18000		

Appearance and Installation Dimensions

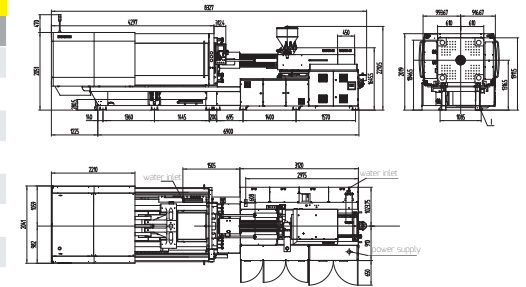

Mold Platen Drawing

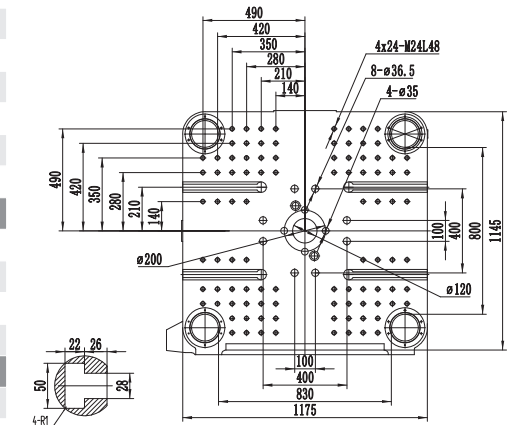

OTHER DIMENSION

BORCHE

STANDARD FEATURES

BORCHE

	Bi90-M	Bi130-M	Bi160-M	Bi200-M	Bi260-M	Bi320-M	Bi400-M	Bi500-M
A(mm)	80	80	90	90	110	110	130	130
B(mm)	80	80	95	95	110	110	130	130
C(mm)	M8	M8	M8	M8	M10	M10	M10	M10
D(mm)	50	50	50	60	70	70	90	90

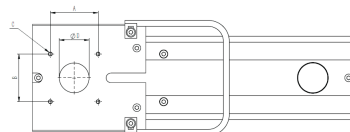

Hopper Dryer Installation Dimensions

	Bi90-M	Bi130-M	Bi160-M	Bi200-M	Bi260-M	Bi320-M	Bi400-M	Bi500-M
A1	17.5	35	35	35	35	35	35	35
A2	52.5	105	105	105	175	175	175	175
B1	140	140	175	175	210	280	350	350
B2	210	245	280	280	350	420	490	490
d	M12	M16	M16	M16	M20	M20	M20	M20

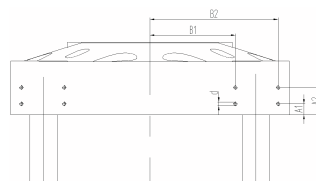

Robot Installation Dimensions

	Bi90-M	Bi130-M	Bi160-M	Bi200-M	Bi260-M	Bi320-M	Bi400-M	Bi500-M
A(template stroke)	320	340	410	465	520	580	655	755
B(maximum die thickness)	360	450	500	550	600	655	720	800
C(minimum die thickness)	130	145	160	180	195	220	245	265
D(nozzle extension distance)	35	35	45	45	45	45	45	50
E(diameter of nozzle hole)	3	3	3	3	3	3	5	5
F(nozzle spherical surface SR)	10	10	10	10	10	10	10	10
G(mold locating hole)	125	125	125	160	160	160	160	200

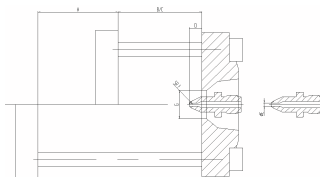

Clamping Unit Schematic Drawing

*No locating ring available

SAFETY UNIT	
1	China New Safety Standard
2	Full guarding in accordance with the "European Machine Directive"
3	Double emergency button
4	Mechanical safety lock(\$200 T)
INJECTION UNIT	
1	Twin carriage structure
2	Balancing twin injection cylinder
3	Wear resistant screw and barrel
4	Chrome plated screw
5	Nozzle centering calibration
6	A/B/C size screw available
7	Double insulation cover for barrel
8	Liner guide for injection and carriage movement
9	Movable sliding rail
10	Ceramic heat band
11	Nozzle safety guard with electric lock
12	High pressure/temperature tube for cooling ring of hooper throat
13	Nonslip embossed aluminum sheet
14	High torque hydraulic motor
15	Screw RPM sensor
16	Screw cold start protection
17	Suck back function
18	5 stages of injection, pressure/speed adjustable
19	3 stages of pressure holding, pressure/speed adjustable
20	3 stages of plasticizing, pressure/speed adjustable
CLAMPING UNIT	
1	Balanced, double, five point toggle locking system
2	Hard chrome plated tie bar
3	Mold platen with T-solt and mounting holes
4	Independent location ring for fixing platen
5	Abrasion resistance strip
6	Centralized lubrication system with end sensor
7	Low pressure mold safety protection
8	Auto clamping force adjustment
9	Mold adjustment by hydraulic motor
10	Multi ejection function
11	Quick change coupling for center platen
12	Robot mounting hole(EU18)
13	Controller height adjustable
14	Product drop chute(\$260T)

CONTROL UNIT	
1	Controller
2	Internet connection port
3	Three color alarm light (red/yellow/green)
4	Data protect lock
5	Electric heating protection by fuse or auto switch
6	Real-time display of injection and plasticize curve
7	Real-time display of servo action curve of mold open and close
8	Injection pressure protection
9	Injection curve monitoring
10	Operation modification record
11	Alarm record
12	I/O status display function
13	Multi-language available(CN/EN standard)
14	Self-diagnosis system
15	SPC quality control
16	Process parameter quick setting
17	Robot interface(including defective product & opening mold signal)
18	Printer connection port(USB17)
19	Auto purge function
20	Timing heating function
HYDRAULIC UNIT	
1	Servo energy saving hydraulic system
2	Low pressure protection
3	Boost clamping
4	Oil level indicator and oil temperature detection
5	Efficient hydraulic oil cooler
6	Charging digital ratio back pressure
7	Oil seal device for oil suction port of oil pump
8	Mightiness iron remover
OTHER UNIT	
1	Borche standard VI color
2	Power socket
3	Adjustable level pads
4	Without hopper
5	With hopper slide
6	Tool box
7	Standard spare parts

OPTIONAL FEATURES

BORCHE

SAFETY UNIT	
1	CE Safety Standard
2	Main power switch with rotation handle
INJECTION UNIT	
1	Bi-metallic screw and barrel
2	PC screw
3	Extended Nozzle
4	Self-seal shut-off nozzle (hydraulic/pneumatic)
5	Spring type shut-off nozzle
6	Ceramic heater band
7	Temperature control of hooper feed throat
8	Carriage transducer
9	V/P switch for mold pressure
10	Stainless hopper
CLAMPING UNIT	
1	Multiple sets of hydraulic core pulling
2	Multiple sets of pneumatic core pulling
3	Hydraulic unscrewing
4	Electric unscrewing
5	Multiple sets of air blast
6	Enlarged mold thickness
7	Mold locking ring with tailored size
8	Graphite copper bush on moving platen
9	Photo sensor for product drop detector(§320T)
10	Water manifold
11	Water distributor
12	Mold platen heat insulation board
13	Manual centralized lubrication for rear platen
CONTROL UNIT	
1	Hot runner control by program, comply with EU14
2	Robot interface, comply with EU12/EU67
3	Core pulling electric interface, comply with EU13
4	UPS power supply
5	Pneumatic-injection electrical interface
6	Cavity pressure detection electrical interface
7	Energy meter
8	Phase loss or phase failure protection for motor
9	Specified power and voltage
10	External voltage transformer
11	Heater band leakage detection
12	Four color alarm light
13	Extra sockets
14	Power stabilizer
15	Mold ejector backward signal

INTELLIGENT EDGE TERMINAL (IMEC)	
1	Temporary authorization of PlasCloud App, basic version
2	Machine Kanban: status, cycle time and output, etc.
3	HMI: M2M & M2H interconnection
4	Process control: real-time setting, history setting
5	Remote support: process parameter, parameter setting
6	Machine health self-diagnosis
HYDRAULIC UNIT	
1	Independent oil temperature control
2	Filter on cooler inlet
3	Ejection during mold open
4	Injection during mold open
5	High pressure bypass oil filter
6	High speed proportional valve for Injection
7	High speed proportional valve for Clamping
8	Oil level low limit alarm
9	Pressure sensor for Injection
10	Enlarged cooler
11	Enlarge one stage motor and pump

Intelligent Unmanned IMM Factory

BORCHE

- 01** Factory Layout-Borche specializes in intelligent IMM factory design. Many intelligent factory cases carried out worldwide in IMM industry.

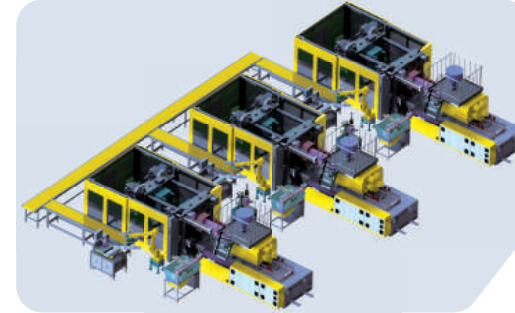

- 02** Flexible Automation -360° visual detection robot operation, automatic assembling, parts insert, polishing and deburring. ...

Visual Detective System

Robot Application (part pick-up, casting insert, assembling, stacking, deburring, degating)

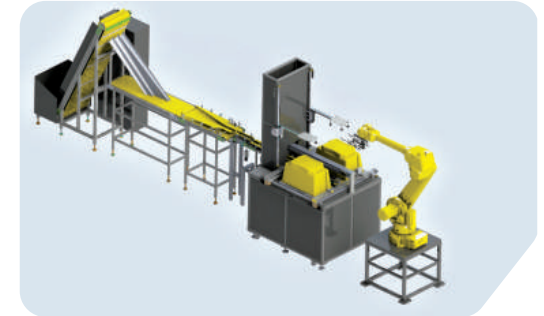

- 03** Intelligent Logistics- AGV, rolling line, automatic packing, wrapper.

